



**AKRAPOVIC RACING & EVOLUTION EXHAUST SYSTEM**  
**for the**  
**YAMAHA YZF R1 (2007-)**

**Congratulations on purchasing an Akrapovic exhaust system. Please read these installation instructions carefully. If you have any trouble installing the system please contact your authorized dealer!**

**IMPORTANT INFORMATION**

**Exclusion of Certain Liability**

1. The manufacturer, importer or dealer shall not be liable for any incidental damage including personal injury or any other damages caused by improper installation or operation of the Akrapovic exhaust system. When installing the Akrapovic exhaust system be careful that the exhaust system does not touch other parts sensitive to high temperature.
2. Akrapovic makes no representation or warranties with regard to damage caused by the improper installation, use and maintenance of the Akrapovic exhaust system. The warranty is limited to defects recognized by our technical department and to normal use, and excludes items subject to normal wear (gaskets and damping wool). The guarantee is void in case of accident, modification, improper or competition use.
3. Do not attempt to install the Akrapovic exhaust system on a motorcycle for which it was not made or tested by Akrapovic.
4. When the exhaust system gets very hot during operation, be careful not to burn yourself on the exhaust system or parts which are in direct contact with it, even when the motor is not running. Also protect other people, especially children, from the injuries mentioned above.
5. In some cases Akrapovic exhaust system kits contain chemical products (ceramic anti-seizing grease; bolt sealant). Handle with care, do not inhale or swallow. Avoid excessive contact with skin, eyes or mucous membranes. Keep out of reach of children.
6. Technical specifications of Akrapovic exhaust systems and related products subject to change without notice.

**Trademarks**

The Akrapovic Exhaust System Technology logo is a registered trademark of Akrapovic d.d.

**Akrpovic website**

Information about Akrapovic exhaust systems and related products is available on the Akrapovic website at:  
**<http://www.akrapovic-exhaust.com/>**

**Copyright**

No part of the Akrapovic exhaust system or its documentation may be reproduced or distributed in any form or by any means without the prior written authorization of the Akrapovic company.





© Akrapovic d.d. All rights reserved.

**Symbols**

The following symbols are used throughout these installation instructions:



## INSTALLATION INSTRUCTIONS

	<b>BEFORE INSTALLING CHECK SCHEMATIC OF THE EXHAUST SYSTEM!</b>
	<b>IF ANY ITEMS IN THE AKRAPOVIC EXHAUST SYSTEM PACKAGE ARE MISSING PLEASE CONTACT YOUR AUTHORIZED DEALER. KEEP THE SCHEMATIC FOR FUTURE REFERENCE.</b>
	<b>THESE INSTALLATION INSTRUCTIONS MUST BE READ CAREFULLY IN ORDER TO ENSURE PROPER INSTALLATION AND OPERATION OF THE AKRAPOVIC EXHAUST SYSTEM.</b>
	<b>THE EXHAUST SYSTEM CAN BE EXTREMELY HOT. ALLOW THE MOTORCYCLE TO COOL DOWN BEFORE BEGINNING INSTALLATION.</b>
	<b>WE ADVISE YOU TO LEAVE INSTALLATION TO A QUALIFIED SERVICEMAN. IMPROPER INSTALLATION MAY RESULT IN A SHORTER LIFETIME OF THE EXHAUST SYSTEM AND/OR DAMAGE TO THE MOTORCYCLE.</b>

### REMOVAL OF STOCK EXHAUST SYSTEM

1. put the motorcycle on a side stand, we recommend a racing stand
2. unlock and remove the rear passengers seat (**Figure 1**)
3. unscrew the bolts from the drivers seat and remove the seat (**Figure 2**)
4. unscrew the bolts from the fastback and remove the fastback (**Figure 3, 4, 5**)
5. unscrew the bolts from the plastic cover of the muffler hanging bracket and remove the cover (**Figure 6**)
6. unscrew and remove the heat shield (**Figure 7, 8, 9**)
7. unscrew the bolt from the link pipe metal clamp (muffler – link pipe connection) (**Figure 10**), the bolt from the muffler hanging bracket and remove the muffler; perform the process on both sides of the motorcycle (**Figure 11, 12**)
8. unscrew the bolts from the rider's footrest bracket and rear brake stop switch – do not disconnect the brake fluid tube! (**Figure 13, 14, 15**)
9. unscrew and remove the lower part of the cowling (**Figure 16, 17, 18**)
10. unscrew and remove the lambda sensor (**Figure 19**)
11. unscrew the bolt from the Y link pipe metal clamp (Y link pipe - collector connection) (**Figure 20**)
12. unscrew the bolts from the Y link pipe metal brackets and remove the Y link pipe (**Figure 21, 22, 23**)
13. remove the middle part of the cowling (**Figure 24, 25, 26, 27**)
14. remove the cover from the servo motor (**Figure 28**), remove the cables from the servo motor (**Figure 29, 30, 31**) and reattach the servo motor cover (**Figure 32**); **do not disconnect the electrical installation of the servo motor!**
15. remove the nuts from the flanges of the stock header tubes and remove the stock headers (**Figure 33, 34**); make sure not to damage the radiator.

### INSTALLATION OF THE AKRAPOVIC RACING OR EVOLUTION EXHAUST SYSTEM

#### **installing the header tubes & collector:**

1. set up the sleeves together with the flanges and springs (**Figure 35, 36**) – make sure they are correctly oriented and that the holes for attaching the springs line up with the loops on the header tubes (**Figure 37**); make sure not to damage the cooling fins
2. insert the header tubes and attach the springs; make sure not to damage the cooling fins (**Figure 38, 39**)
3. tighten the flanges; make sure not to damage the cooling fins (**Figure 40**)
4. make sure the header tubes are not touching the engine, water cooler, other tubes, electrical installations etc.

#### **installing the independent link pipe:**

1. remove the stock metal bush from the Y link pipe hanging bracket (**Figure 41**)
2. slide the Y link pipe onto the collectors (**Figure 42**)
3. attach the springs on the Y link pipe (Y link pipe – collectors joint) (**Figure 43**)
4. reattach the stock lambda sensor (**Figure 44**)
5. hand tighten the Akrapovic Y link pipe to the upper stock hanging bracket; use stock bolt and washer (**Figure 45**)
6. make sure the Y link pipe is not touching the engine or frame of the motorcycle

#### **installing the mufflers:**

1. correctly position the carbon-fiber clamp and slide it onto the muffler. **WARNING:** open the clamp to slightly wider than the diameter of the outer sleeve of the muffler – do not scrape it along the muffler outer sleeve! (**Figure 46**)
2. position the muffler correctly and slide it onto the outlet side of the Y link pipe (**Figure 47**)
3. fasten carbon-fiber clamp onto the stock chassis hanging bracket on the sub-frame; use the bolt, washer and aluminium spacer supplied in the Akrapovic kit. Do not fully tighten. Make sure the additional parts from the Akrapovic kit are correctly installed. (**Figure 48, 49, 50, 51**)
4. position and attach the spring (**Figure 52**)
5. perform the process on both sides of the motorcycle
6. make sure the mufflers are not touching other parts of the motorcycle
7. reattach the stock heatsheald; use Akrapovic aluminium spacer and bolt (**Figure 53, 54, 55, 56**)

#### final installation:

1. tighten the bolts on all of the brackets and clamps to which the exhaust system is attached
  2. clean grease spots:
    - a. muffler – titanium outer sleeve: use a soft cloth sprayed with a multi-purpose spray lubricant (WD-40 or equivalent)
    - b. muffler – carbon-fiber outer sleeve: use a soft dry cloth
    - c. muffler – carbon-fiber outlet cap: use a soft dry cloth
    - d. titanium link pipes (muffler and Y link pipe): use a soft cloth sprayed with a multi-purpose spray lubricant (WD-40 or equivalent)
    - e. stainless steel link pipe (muffler and Y link pipe): use a soft cloth sprayed with a contact cleaner, then wipe with a soft dry cloth
    - f. titanium header tubes + collectors : use a soft cloth sprayed with a multi-purpose spray lubricant (WD-40 or equivalent)
    - g. stainless steel header tubes + collectors :use a soft cloth sprayed with a contact cleaner, then wipe with a soft dry cloth
- Cleaning will prevent spots from burning onto the surface. Do not use aggressive chemical cleaners, because they can damage the sticker.
3. replace all of the dismantled stock parts and cowlings in the reverse order from the order in which they were removed
  4. position of the installed Akrapovic Racing or Evolution system (**Figure 57**).

**Check the operation of the brakes and suspension. Make sure all the bolts are sufficiently tightened. In case the exhaust system touches the cowling or other parts repeat the adjustment of the exhaust system or contact your authorized dealer.**

**! IT IS NORMAL IF WHITE SMOKE COMES OUT OF THE MUFFLER ON FIRST OPERATION.**

**! DO NOT STAND BEHIND THE MUFFLER ON FIRST OPERATION.**

**! DO NOT USE AUTOMOTIVE WHEEL CLEANERS OR ANY CLEANING PRODUCTS WHICH CONTAIN ACIDIC ADDITIVES TO CLEAN AKRAPOVIC EXHAUST SYSTEMS.**

#### MAINTENANCE OF THE AKRAPOVIC EXHAUST SYSTEM

1. Clean the titanium muffler outer sleeve with a multi-purpose spray lubricant (WD-40 or equivalent ) and carbon fiber outer sleeve with soft and dry cloth. Do not use aggressive chemical cleaners, because they can damage the sticker. A change in the color of the exhaust system is normal due to the high temperatures.
2. The wearing out of the muffler silencing material depends on the type of the motor and riding style. Contact your dealer/serviceman if visible changes appear on muffler's outer sleeve or the noise level is increased.
3. Periodically ensure that all the bolts and springs are sufficiently tight.

#### Photos:



Figure 1



Figure 2



Figure 3



Figure 4



Figure 5



Figure 6



Figure 7



Figure 8



Figure 9



Figure 10

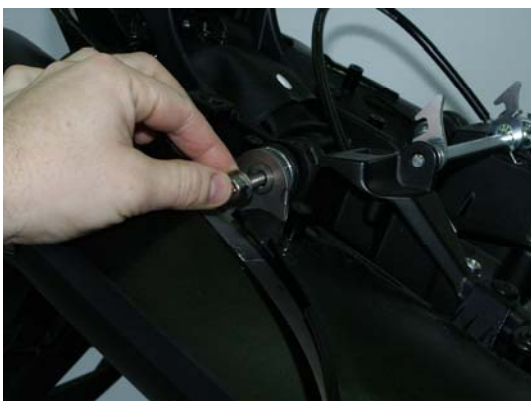

Figure 11



Figure 12



Figure 13

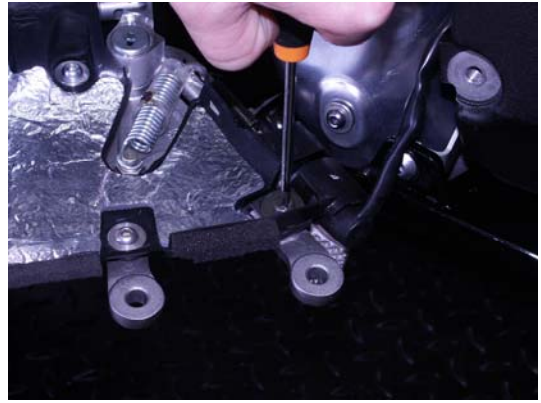

Figure 14

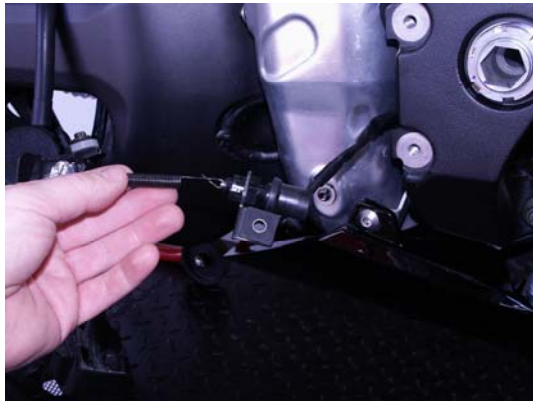

Figure 15

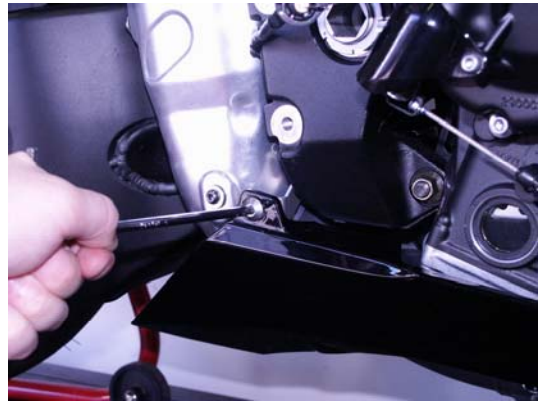

Figure 16



Figure 17



Figure 18



Figure 19



Figure 20



Figure 21



Figure 22



Figure 23



Figure 24



Figure 25

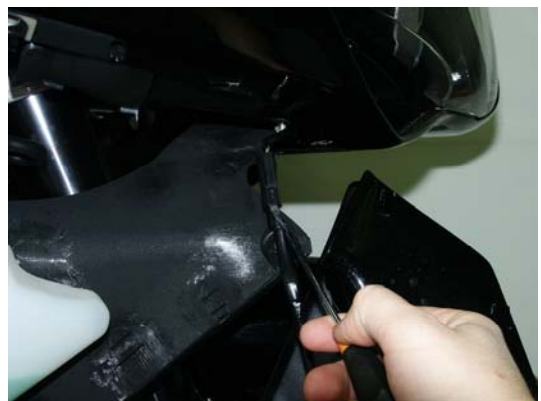

Figure 26



Figure 27



Figure 28



Figure 29



Figure 30



Figure 31



Figure 32

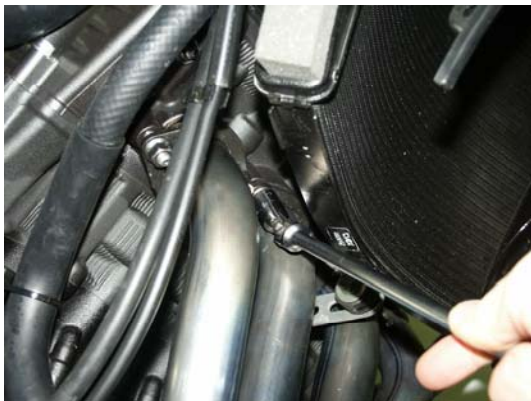

Figure 33



Figure 34



Figure 35



Figure 36



Figure 37



Figure 38



Figure 39



Figure 40



Figure 41



Figure 42



Figure 43



Figure 44





Figure 45



Figure 46



Figure 47



Figure 48



Figure 49



Figure 50



Figure 51



Figure 52



*Figure 53*



*Figure 54*



*Figure 55*



*Figure 56*



*Figure 57*

# YAMAHA YZF 1000R1 2007/ RACING LINE (OPEN)

Product code: S-Y10R9-DTC  
S-Y10R9-DTT

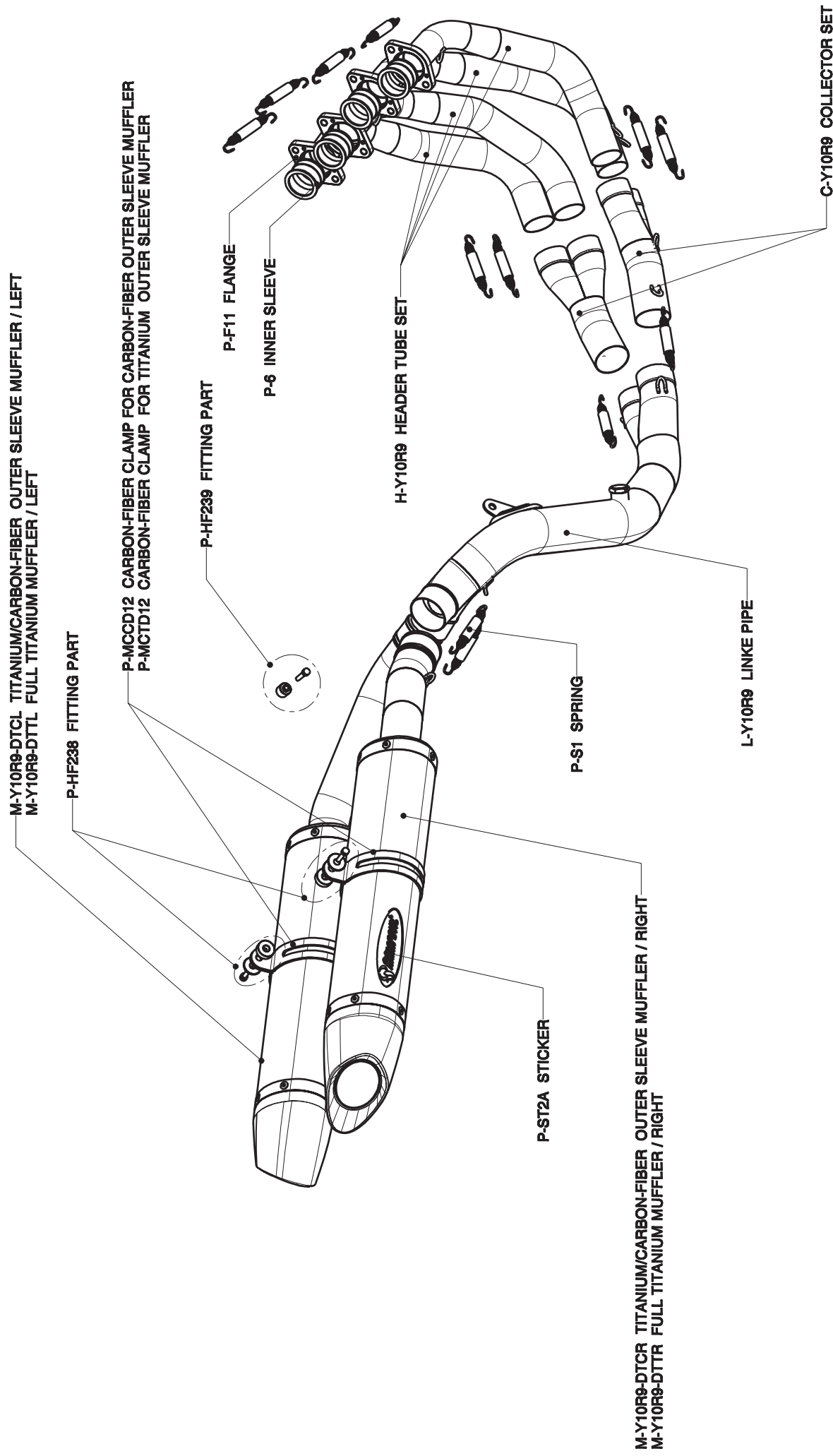

# YAMAHA YZF R1 2007/ RACING LINE WITH NOISE DAMPER

Product code: S-Y10R9-DTC/1  
S-Y10R9-DTT/1

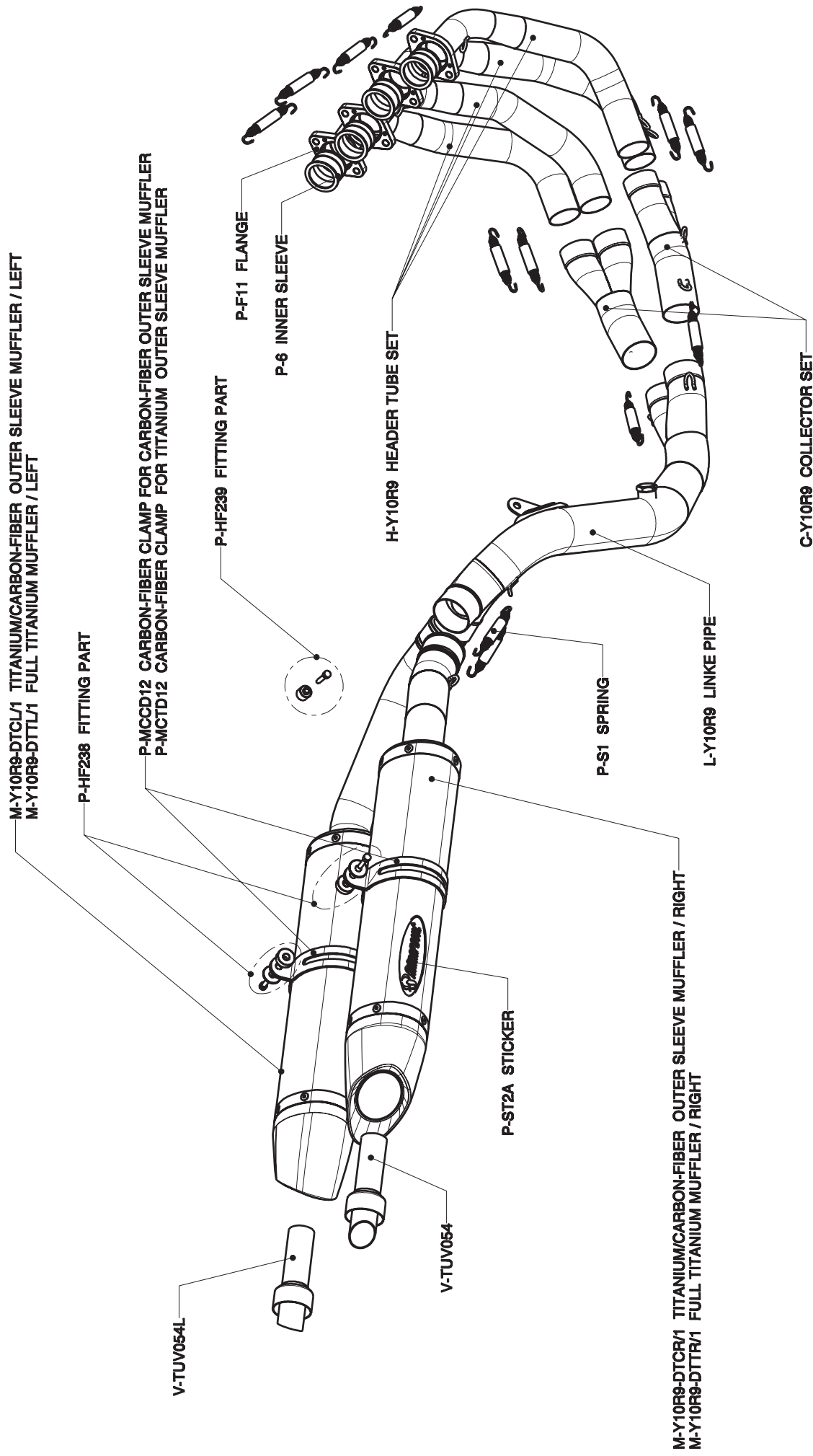

# YAMAHA YZF R1 2007/ EVOLUTION LINE (OPEN)

Product code: S-Y10RFT9T-DTC  
S-Y10RFT9T-DTT

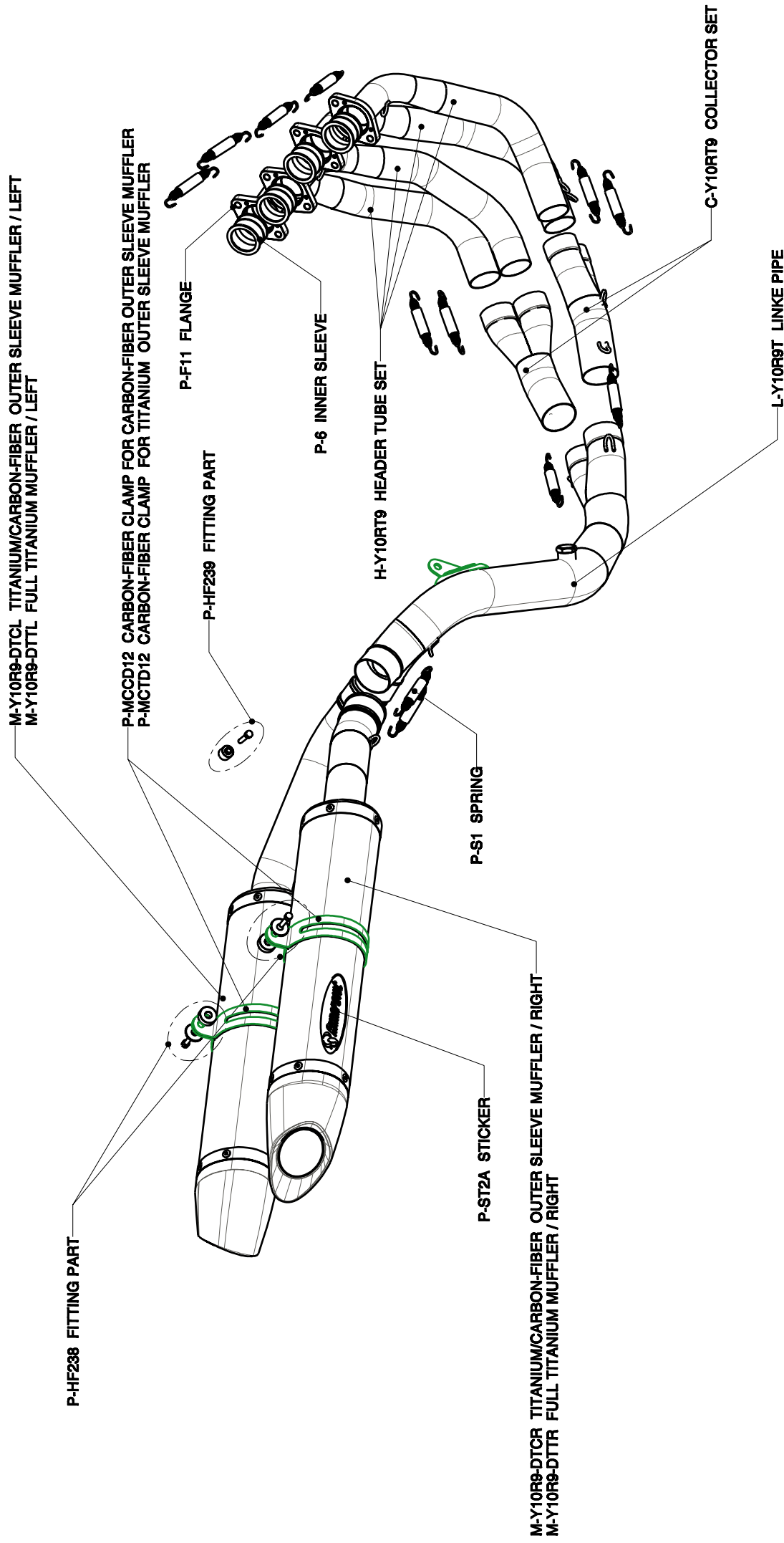

# YAMAHA YZF R1 2007/ EVOLUTION LINE WITH NOISE DAMPER

Product code: S-Y10RFT9T-DTC/1  
S-Y10RFT9T-DTT/1

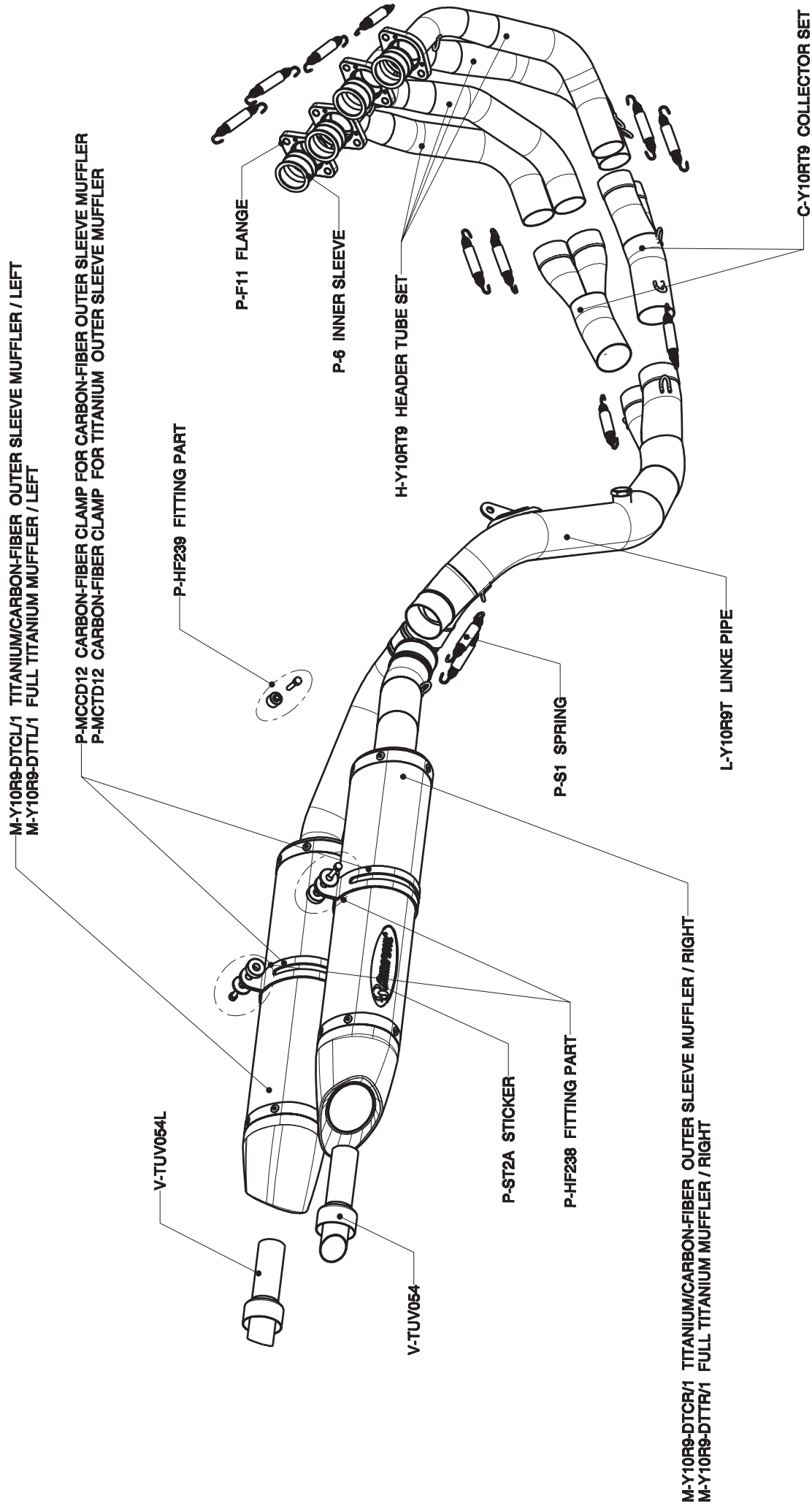

**YAMAHA YZF R1 2007/ Complete exhaust system/ EVOLUTION LINE tube set with Street legal SLIP ON Mufflers, Model year: 2007**

**Product code: S-Y10R10-DTC/1  
S-Y10R10-DTT/1**

WARNING! IN CASE OF COMBINATION WITH EVOLUTION TUBE SET THE SLIP-ON HOMOLOGATION IS NOT VALID!

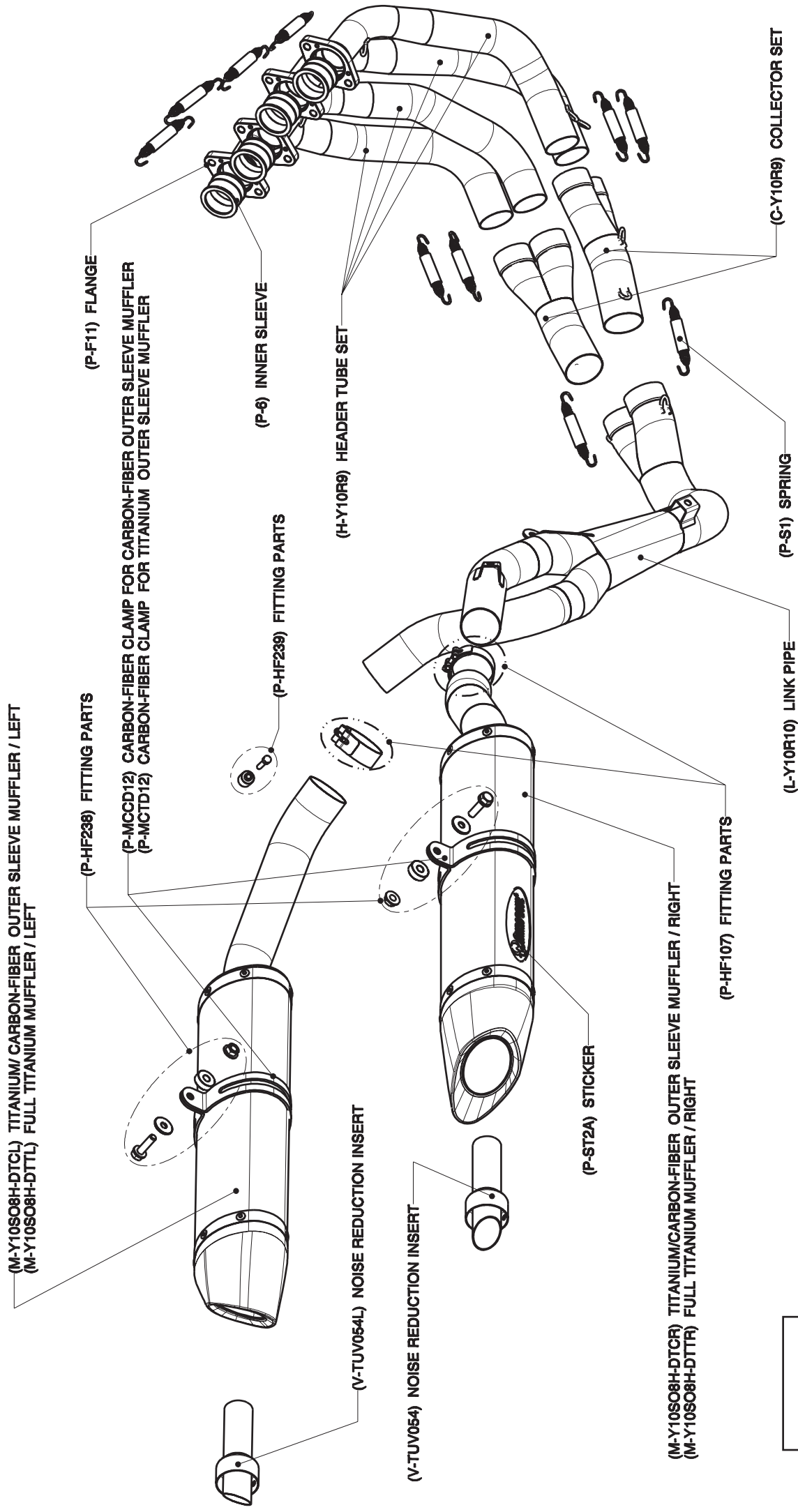

**WARNING:**

Please note that certain aftermarket exhaust systems may not comply with applicable California laws and regulations, and may therefore be prohibited for use on California highways or roads, or on roads or vehicles otherwise subject to emissions control requirements.

Akrapovič exhaust systems for automobiles and motorcycles mounted downstream of the catalytic converter (also known as “cat-back systems”) are considered “replacement parts” in California by the California Air Resources Board (CARB), and do not require an exemption or executive order from CARB to be sold in California. However, California prohibits the use of any aftermarket exhaust system that modifies, removes or replaces original equipment catalysts, unless CARB has issued an Executive Order as to such part or system.

Further, Akrapovič parts or exhaust systems used or intended for use on “racing vehicles” (i.e. a competition vehicle used exclusively for competition on closed-course circuits) do not require an exemption or Executive Order from CARB to be sold in California. However, such parts are prohibited from use on California public highways or roads, even if occasionally used “off-road.”